

Stainless steel 1.4401 (W 5), band width 9 mm.

Worm drive type.

For all standard applications where high clamping forces are normally distributed.

|                                 |   |
|---------------------------------|---|
| Material<br>Hexagon-head screws | Stainless steel 1.4401 (W 5)<br>a/f 7, with integrated cross-tip,<br>Stainless steel 1.4401 (W 5) |
|---------------------------------|---|

#### Worm drive hose clamps, stainless steel 1.4401

| Art. No. | Ident No. | Clamping range<br>mm | Band width<br>mm |
|----------|-----------|----------------------|------------------|
| 158 A-ES | 114225    | 8.0 – 12.0           | 9.0              |
| 158 B-ES | 114226    | 10.0 – 16.0          | 9.0              |
| 158 C-ES | 114227    | 12.0 – 20.0          | 9.0              |
| 158 D-ES | 114228    | 16.0 – 25.0          | 9.0              |
| 158 E-ES | 114229    | 20.0 – 32.0          | 9.0              |
| 158 G-ES | 114230    | 25.0 – 40.0          | 9.0              |
| 158 J-ES | 114231    | 32.0 – 50.0          | 9.0              |
| 158 K-ES | 114232    | 40.0 – 60.0          | 9.0              |
| 158 L-ES | 114233    | 50.0 – 70.0          | 9.0              |
| 158 M-ES | 114234    | 60.0 – 80.0          | 9.0              |
| 158 N-ES | 114235    | 70.0 – 90.0          | 9.0              |
| 158 P-ES | 114236    | 80.0 – 100.0         | 9.0              |
| 158 R-ES | 114237    | 90.0 – 110.0         | 9.0              |



158 G-ES



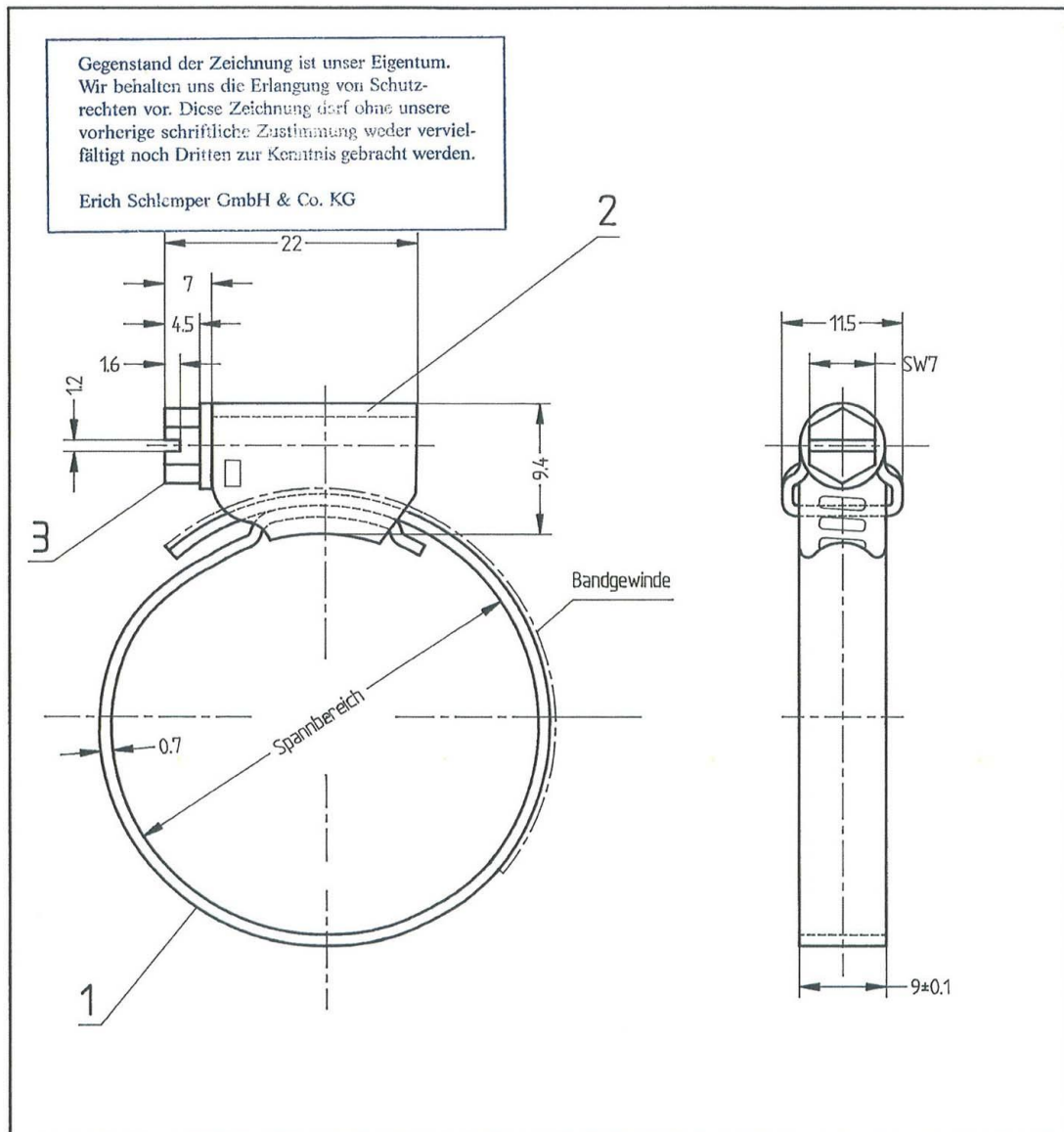

| 3     | 1        |       | Schraube 5.9 x 216   | IEW - 5001                          |  |
|-------|----------|-------|----------------------|-------------------------------------|--|
| 2     | 1        |       | Gehäuse Typ OB 9 mm  | 020 - 02 - 01 - 02 . 01             |  |
| 1     | 1        |       | Band Typ OB 9 mm     | 020 - 01 - 02 - 02 . 02 (Presserei) |  |
| Pos.  | Menge    | Einh. | Benennung            | Norm/Kurzbezeichnung                | Werkstoff/Art. Nr.   |
|       |          |       | (Zul. Abw.)          | (Oberfläche)                        | Maßstab  |
|       |          |       | 2768-f               |                                     | Bildliche Darstellung  |
|       |          |       |                      |                                     | (Gewicht)  |
|       |          |       |                      |                                     | (Werkstoff) W3 { 14301 }   |
|       |          |       |                      |                                     | W4 { 14301 }   |
|       |          |       |                      |                                     | W5 { 14401 }   |
|       |          |       | Datum                | Name                                | (Benennung)  |
|       |          |       | Bearb. 16.11.00      | Ga.                                 | <b>Ideal</b><br><b>Schlauchschelle Typ OB</b><br><b>Größe <math>\phi</math> 20 bis 45 mm</b> |
|       |          |       | Gepr. 16.11.00       | Sa.                                 |  |
|       |          |       | Norm                 |                                     |  |
|       |          |       | ERICH SCHLEMPER GmbH |                                     | (Zeichnungsnummer)   |
|       |          |       |                      |                                     | 020 - SCH - 02 . 00  |
| Zust. | Änderung | Datum | Name                 | Urspr.                              | Ers. für:  |
|       |          |       |                      |                                     | Ers. durch:  |
|       |          |       |                      |                                     | Blatt 1  |
|       |          |       |                      |                                     | Bl. 1  |

